

quartos Brasileiros

- PASSEIO NA HISTÓRIA -



- INFLUÊNCIAS DEIXADAS PELO PASSADO -





A **definição** mais comum de um quarto é a que o relaciona a um cômodo qualquer de um **edifício**. Normalmente, porém, a palavra costuma ser usada como sinônimo para um **dormitório**, especificamente. O quarto geralmente é utilizado para **descansar**. O mobiliário associado a um quarto costuma ser uma **cama**, as **escrivaninhas** a acompanhar a cama, uma **cadeira** ao fim da cama e **armários** para colocação da roupa.

Quando temos uma casa de banho dentro de um quarto, chama-se a este quarto de **suíte**. A casa de banho é de alguma forma exclusiva de uso ao usufrutuário do quarto.

Historicamente falando, *alcova* é um quarto sem janelas, comum nas casas coloniais brasileiras. Em função da falta de ventilação, costumavam ser mais úmidos e sujeitos à presença de mofo. Por não terem janelas. Costumava ser o cômodo mais próximo da porta de entrada, tendo a finalidade de quarto de hóspedes ocasionais: caixeiros-viajantes e desconhecidos distintos, quando abrigados pelo senhor da casa, faziam o pernoite na alcova, com vela, penico e jarra de água, e a porta trancada a chave para ser aberta pela manhã. A expressão *alcoviteiro* dizia respeito ao sujeito sem posses, necessitado dos favores de alcova.

- QUARTO - 70'S +

Ana Carolina Junqueira
Andressa Valverde



Muito coloridos

Quase todos os tecidos eram estampados e quase tudo tinha tecido



ADIEL ROCHA

- QUARTO - 70'S +



Ana Carolina Junqueira
Andressa Valverde



EFEITO DE COR

**JOGO DE PERSPECTIVA NO
QUARTO, COM OS TONS DE
LARANJA E AMARELO**

- QUARTO - 80'S +

Ana Carolina Junqueira
Andressa Valverde



ESTILO DE FORA
Inspiração inglesa

-
uso de estampas
florais

Sais com pregas

Sobreposições



**CORTINAS COM
FARTO TECIDO**

**CARPETES ALTOS -
SINAL DE CONFORTO**

Começou a limpar os
exageros da época
anterior

SANDRA MONTEIRO DE BARROS E ROSELY SILVAROLLI

- QUARTO - 90'S +

Ana Carolina Junqueira
Andressa Valverde



Mesas diferentes

-
Aboliu-se a obrigatoriedade de criados mudos e luminárias idênticos

Marcenaria sob medida / LUZ NA MEDIDA

-
Painéis emoldurando a cama, abrindo espaço para obras de artes, que por sua vez, pedem uma boa iluminação

MÁXIMO CONFORTO

-
Home theater chega aos quartos
Quarto vira uma segunda sala

Necessidade de abrigar aparelhos e área de trabalho



- QUARTO - 90'S +

Ana Carolina Junqueira
Andressa Valverde

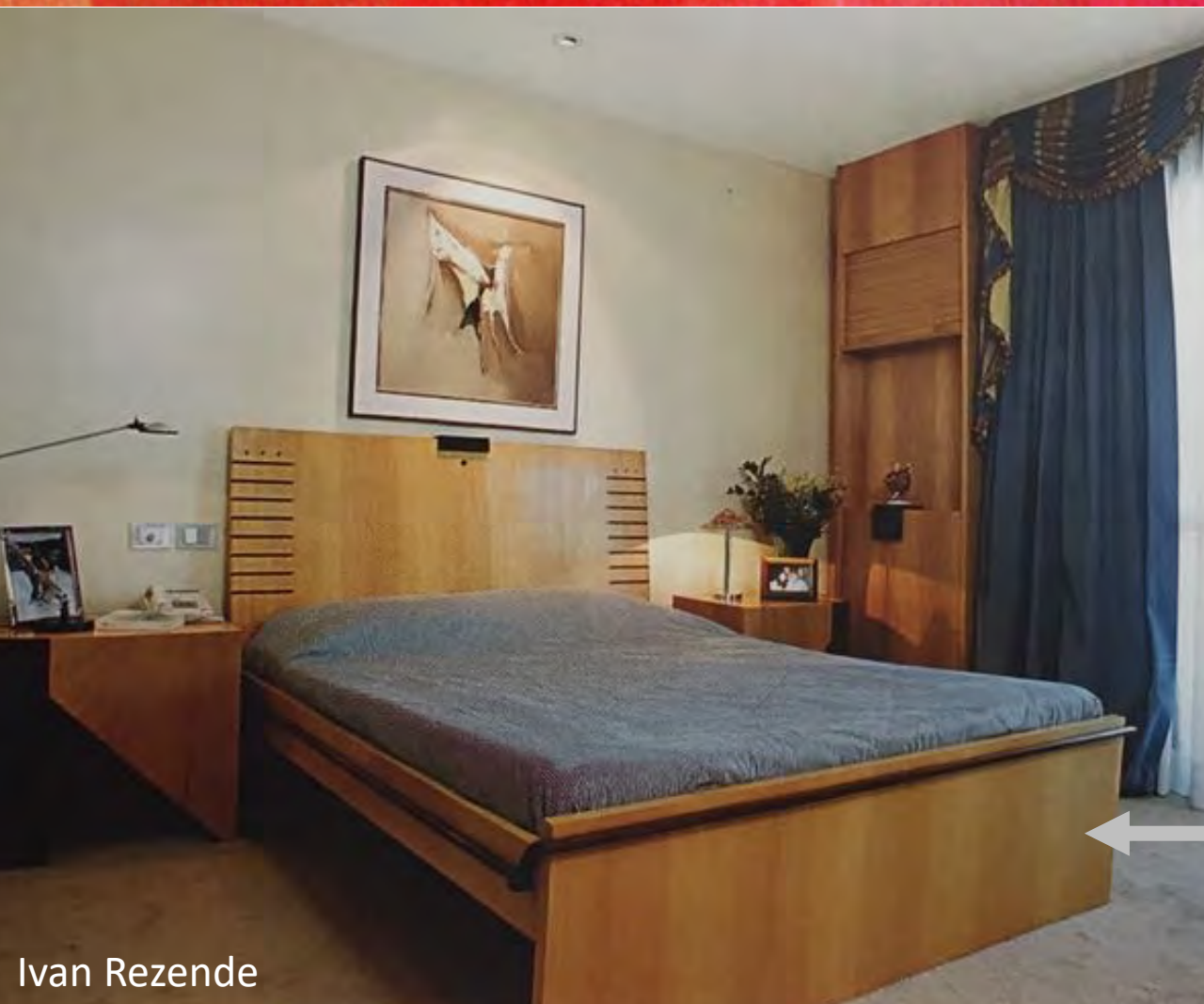

Ivan Rezende

Madeira DA DÉCADA
-
ESCOLHA DE PAU-MARFIM COMO MADEIRA



Fida aude

CAMA DESLIZANTE
-
USO DE RODIZIOS, COMO UMA FORMA DE ganhar
espaço

- QUARTO - 2000'S +



Ana Carolina Junqueira
Andressa Valverde



Ao natural

-

**O Piso de madeira
convida aos pés descalços**

**USO DE CORES, EM GERAL,
SUAVES**



A CARA DO DONO
-
Grafite chega as casas



A CARA DO DONO
O rock está na veia do morador e também em seu quarto. O grafite chegou à casa, às vezes em telas, como a de Sérgio Astral, exposta acima da cabeceira de resina sobre painel de laca brilhante. Projeto da arquiteta Paula Magnani.

- QUARTO - 2000'S +



Ana Carolina Junqueira
Andressa Valverde



NOVO FORMATO
As cabeceiras nunca foram tão variadas em forma, cores e materiais. Este modelo se estende por 3,90 m de comprimento em placas estofadas e recobertas de linho, formando um belo jogo. Banco de Sergio Rodrigues no projeto de Regina Adorno.

Novo formato
-
Cabeceira variadas

- QUARTO - 2000'S +



Ana Carolina Junqueira
Andressa Valverde

FIM DAS BARREIRAS

-
LOFT

Revoluções
tecnológicas

-
Área de trabalho virou
portátil



FIM DAS BARREIRAS

Um loft, com amplos espaços abertos, ainda frequenta os sonhos de muita gente. No projeto do arquiteto Vitor Penha, o quarto exibe um colchão sobre um estrado de ipê. Aos pés da cama, desliza um móvel com rodízios.

- QUARTO - 2000'S +



Ana Carolina Junqueira
Andressa Valverde

Em módulos

-

Peças prontas em módulos, parecendo marcenaria sob medida



Peças prontas
parecem feitas
com exclusividade

EM MÓDULOS Parece marcenaria sob medida, mas cabeceiras extensas como esta, de pau-marfim com acabamento canela, já são encontradas prontas. Um nicho central acomoda itens do dia a dia. Projeto de Gabriela Prado, Eliane Zogbi e Veridiana Zobar.

Gabriela Prado, Eliane Zogbi e Veridiana Zobar

QUARTOS
CONTEMPORÂNEOS
- PROJETOS EXECUTADOS -



- QUARTO CONTEMPORÂNEA - 2010'S +



Ana Carolina Junqueira
Andressa Valverde



- QUARTO CONTEMPORÂNEA - 2010'S +



Ana Carolina Junqueira
Andressa Valverde



Andressa Fonseca



Pinterest

- QUARTO CONTEMPORÂNEA - 2010'S +

Ana Carolina Junqueira
Andressa Valverde



RESTORATION HARDWARE

- QUARTO CONTEMPORÂNEA - 2010'S +

Ana Carolina Junqueira
Andressa Valverde



BRUNA MACIEL E LETÍCIA LOUREIRO



CRISTIANE PASSOS

- QUARTO CONTEMPORÂNEA - 2010'S +



Ana Carolina Junqueira
Andressa Valverde



- QUARTO CONTEMPORÂNEA - 2010'S +

Ana Carolina Junqueira
Andressa Valverde



- QUARTO CONTEMPORÂNEA - 2010'S +

Ana Carolina Junqueira
Andressa Valverde



Leila dionizio

Paula NEDER

- QUARTO CONTEMPORÂNEA - 2010'S +



Ana Carolina Junqueira
Andressa Valverde



KATIE HODGES



CAROL CANTELLI

- QUARTO CONTEMPORÂNEA - 2010'S +



Ana Carolina Junqueira
Andressa Valverde



Paula Neder

- QUARTO - EQUIPAMENTOS



Ana Carolina Junqueira
Andressa Valverde



- QUARTO - EQUIPAMENTOS

Ana Carolina Junqueira
Andressa Valverde



- QUARTO - ERGONOMIA + FLUXO

Ana Carolina Junqueira
Andressa Valverde

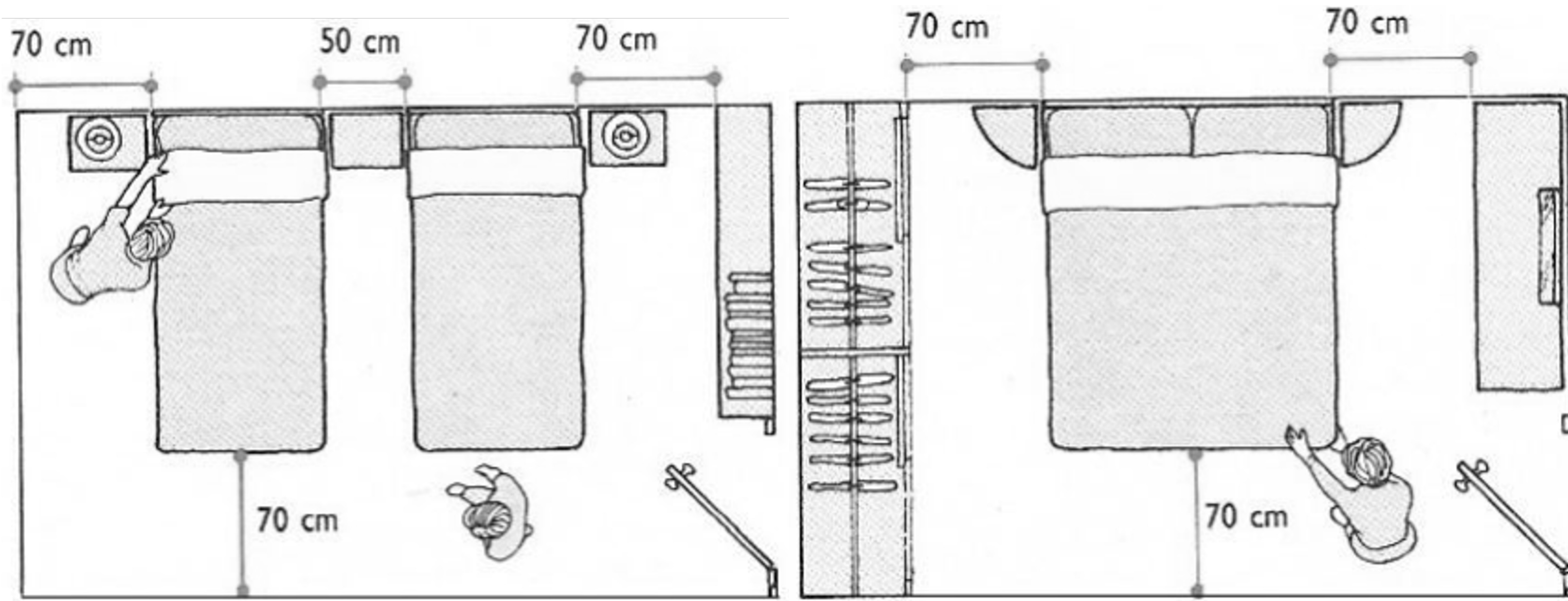

- QUARTO - ERGONOMIA + FLUXO

Ana Carolina Junqueira
Andressa Valverde

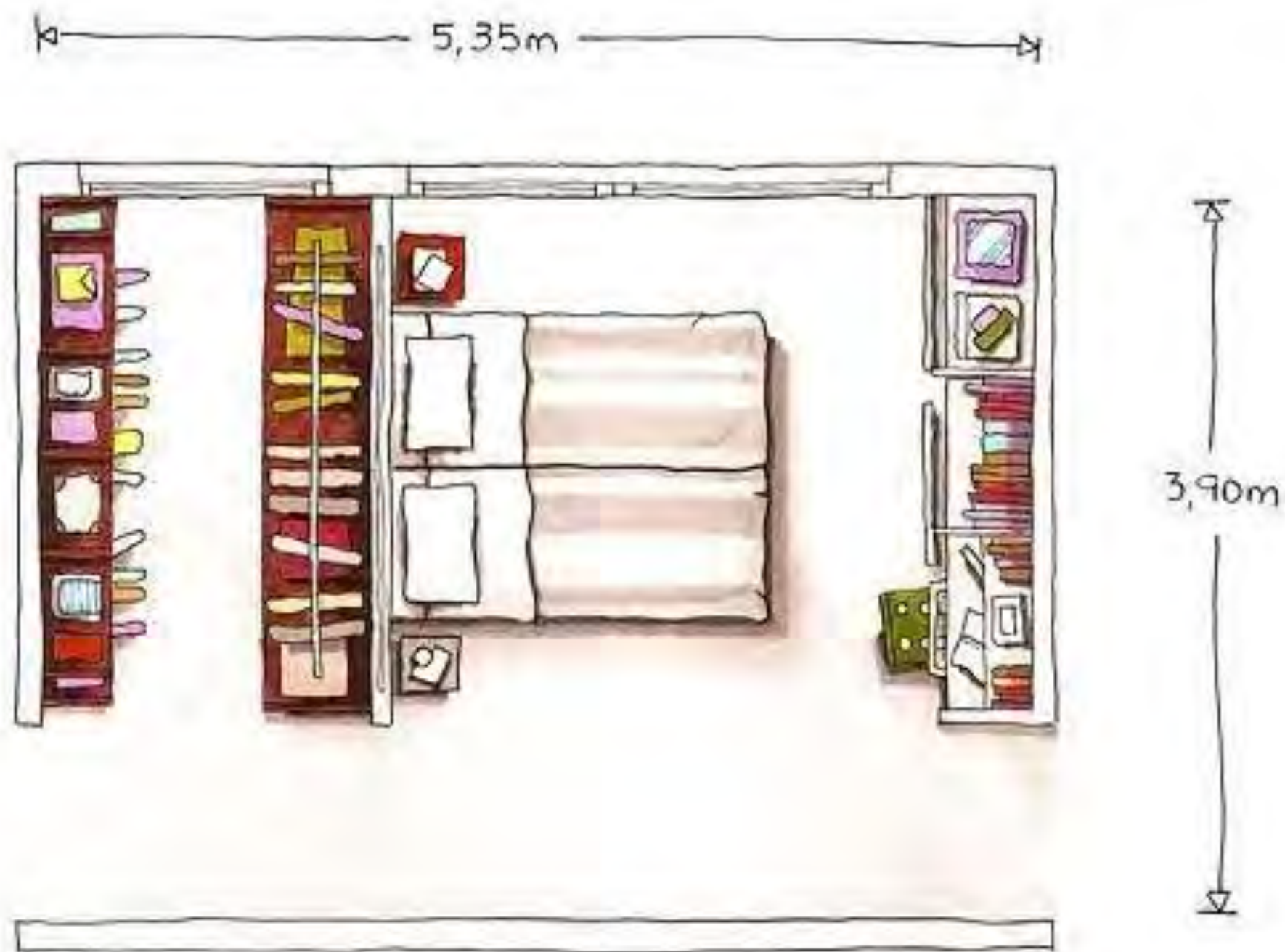

- QUARTO - ERGONOMIA + FLUXO

Ana Carolina Junqueira
Andressa Valverde

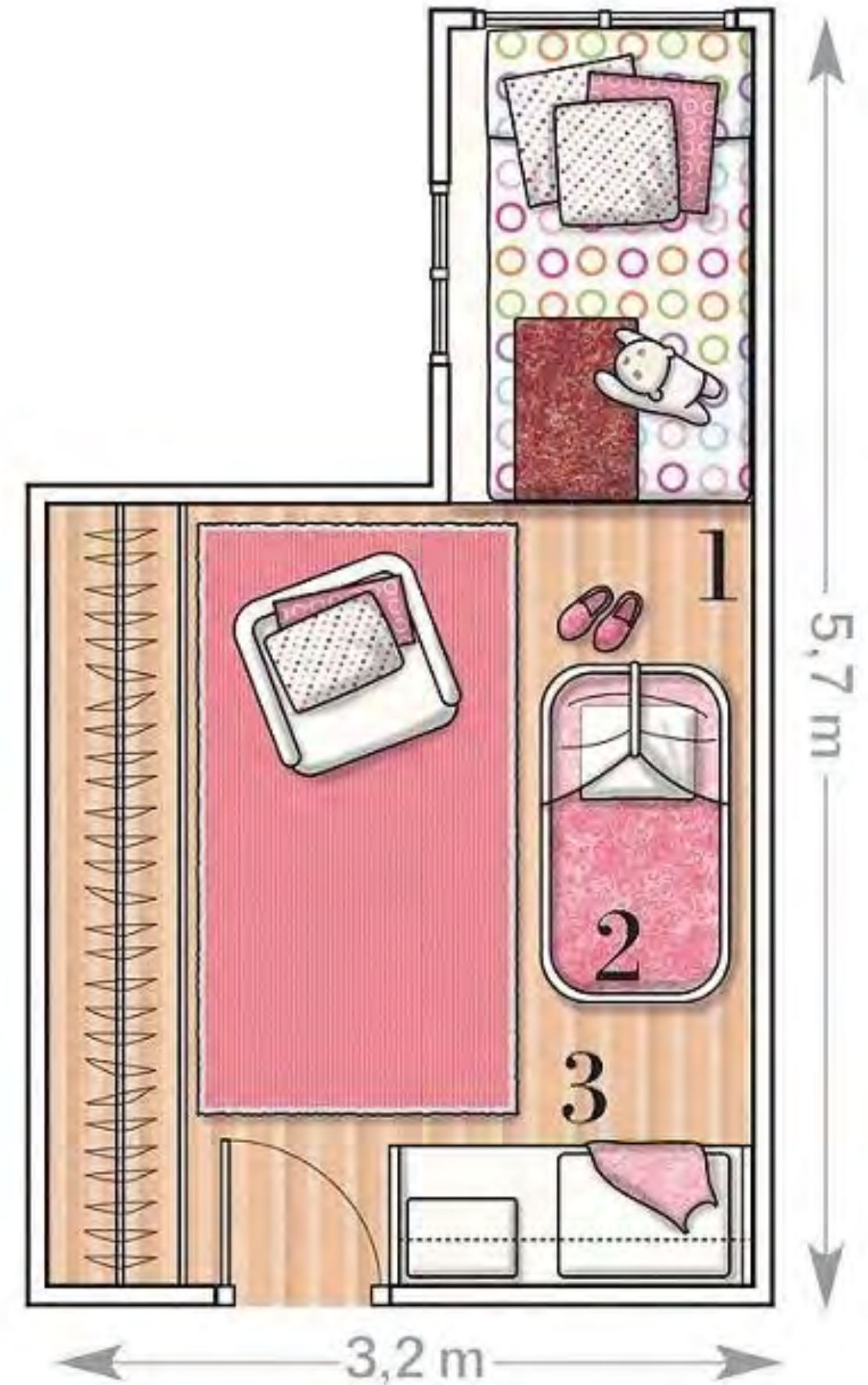
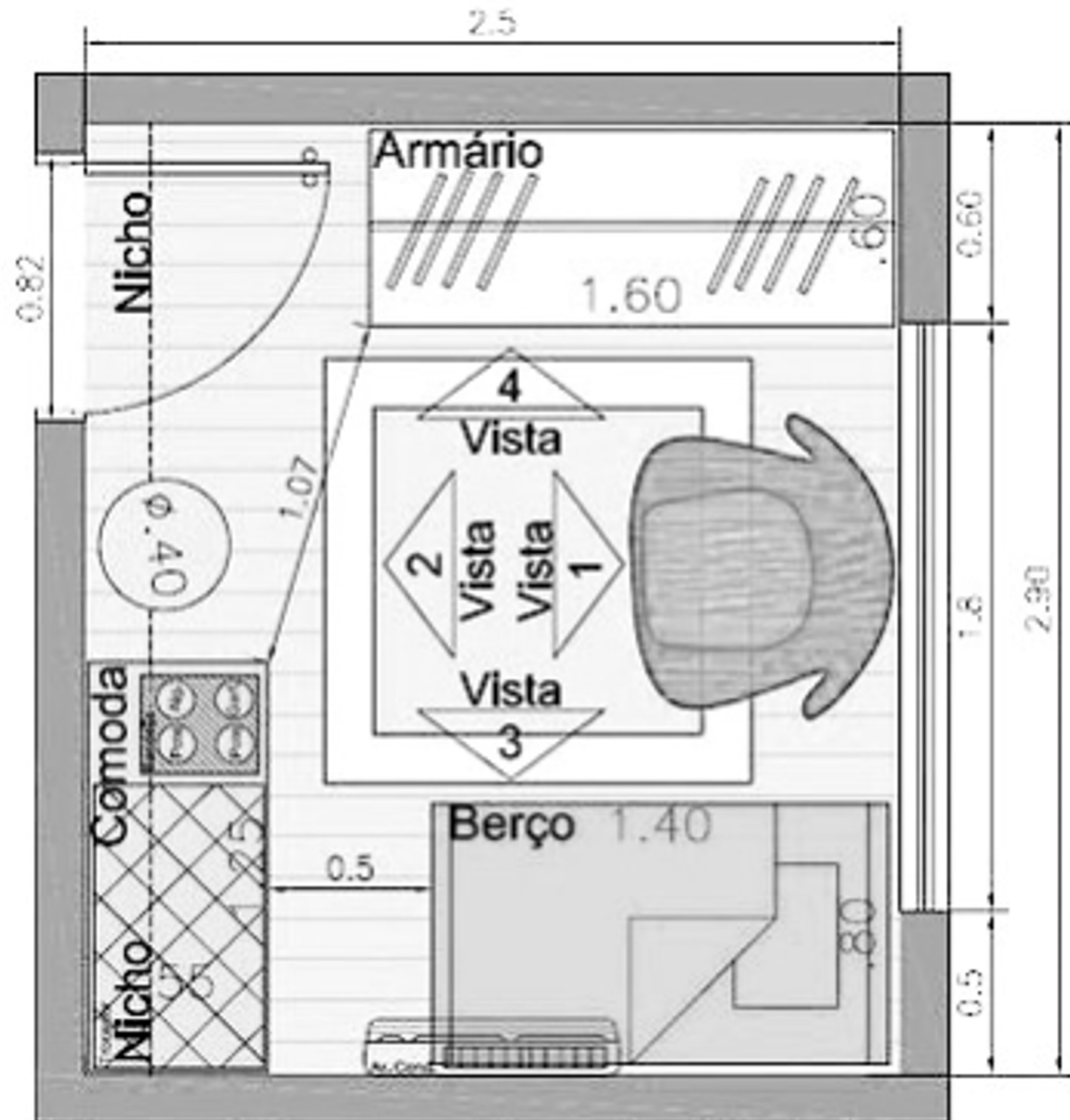

Quarto de Bebê

- QUARTO - ERGONOMIA

Ana Carolina Junqueira
Andressa Valverde

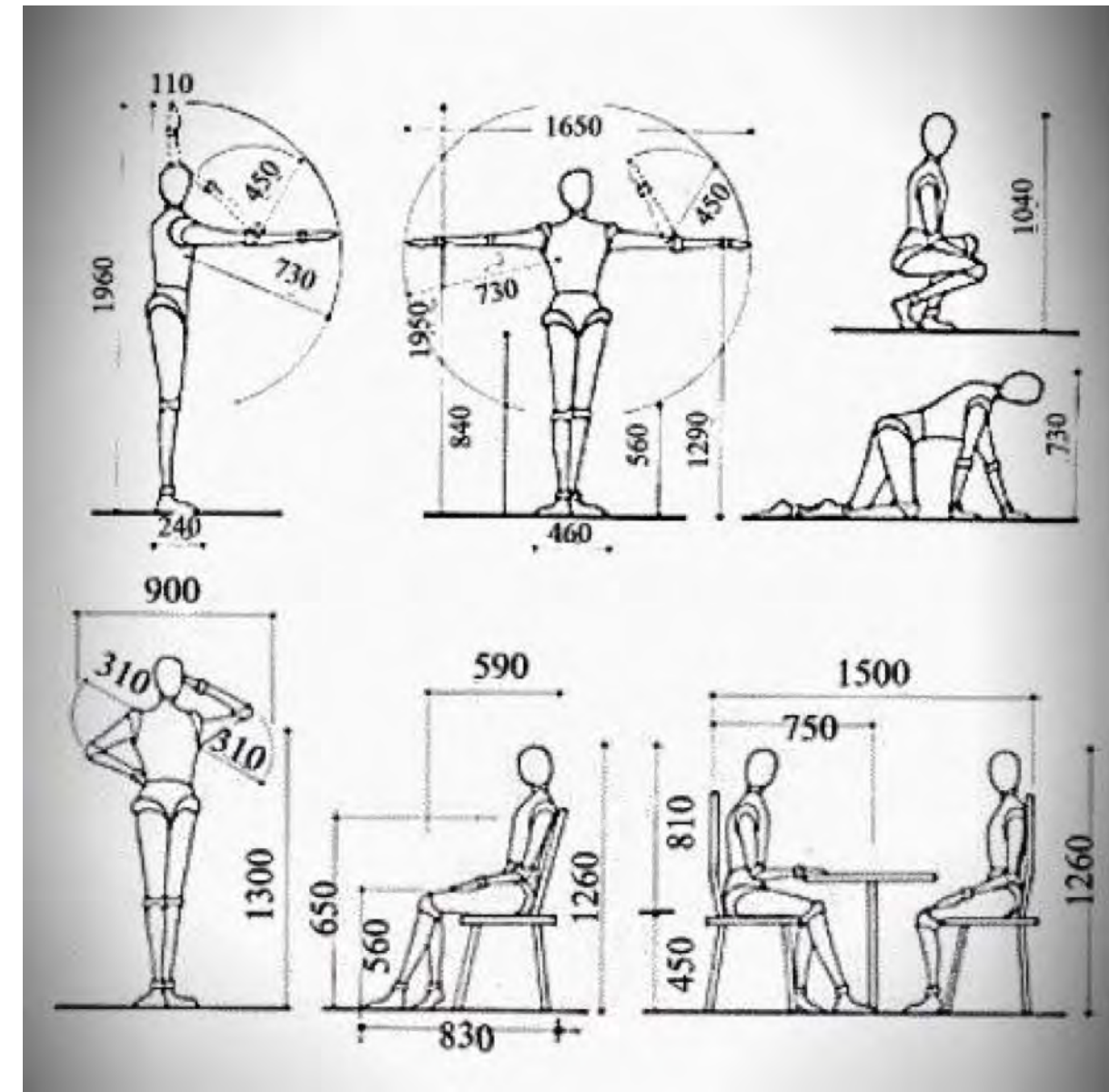
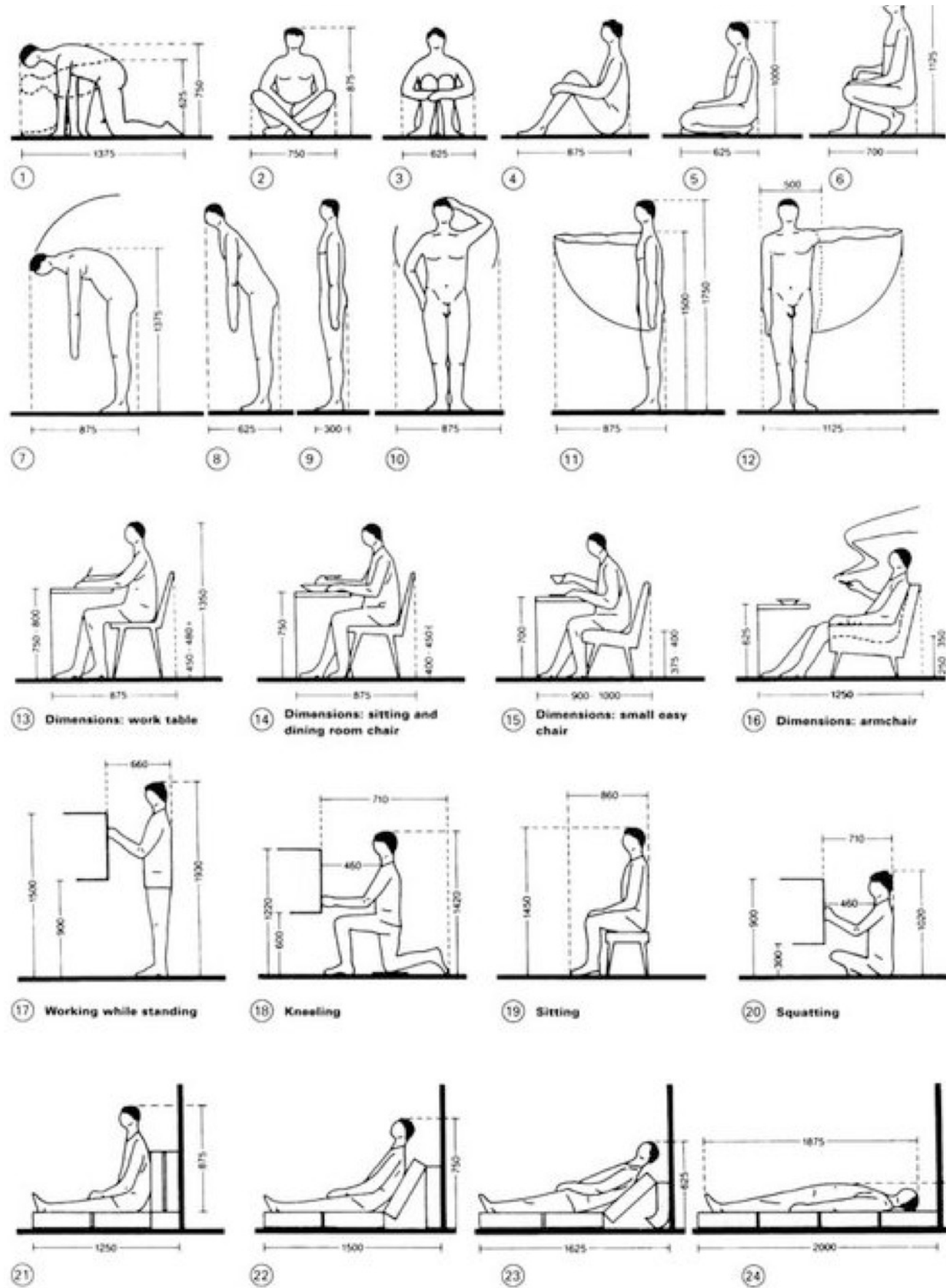

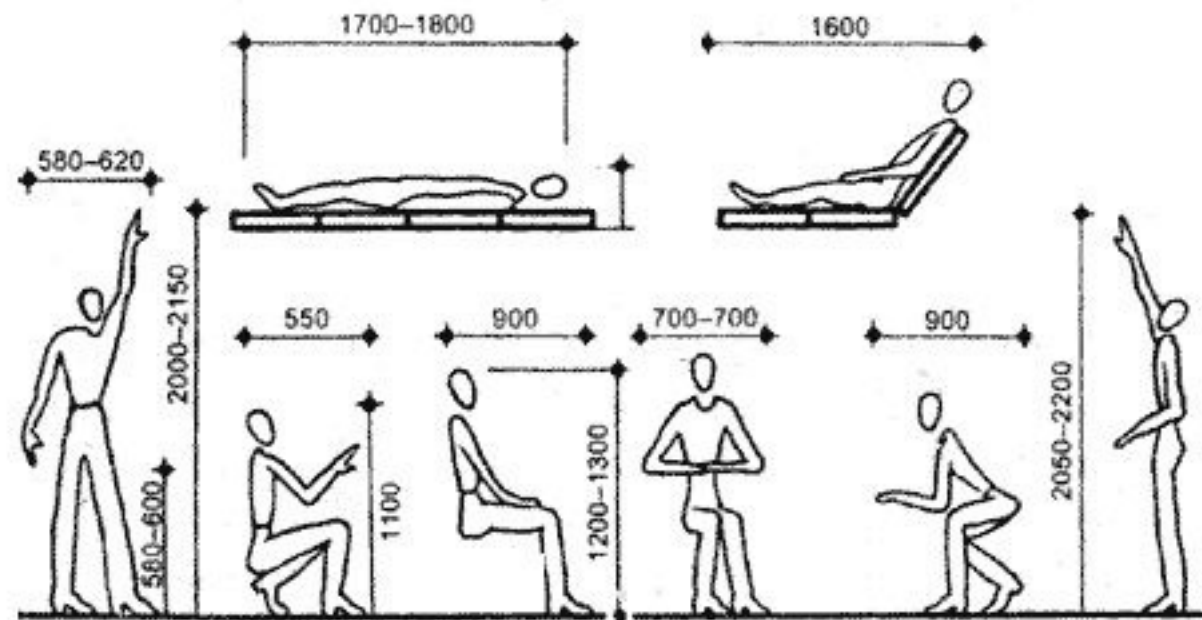

Altura da Pessoa X Plataforma de Trabalho

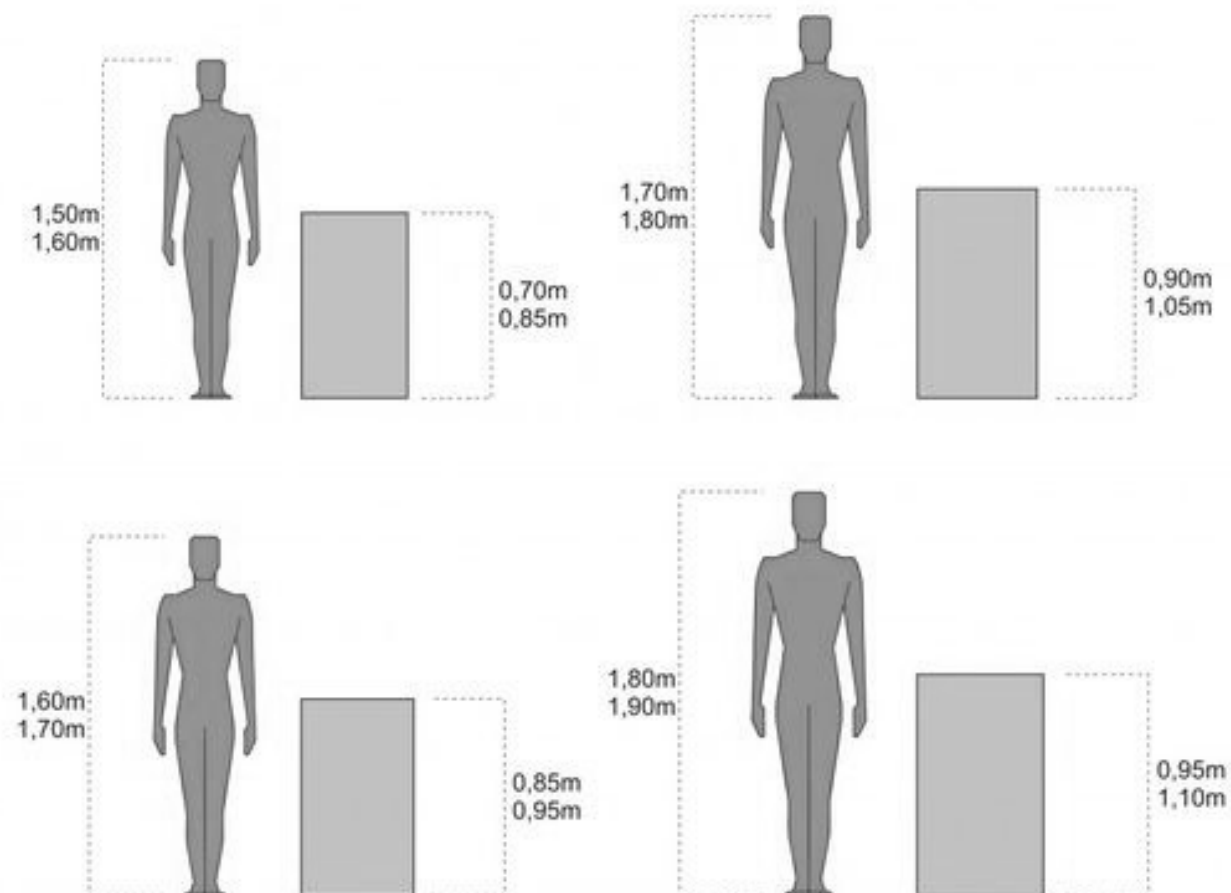

Shelves

Commentary page 33

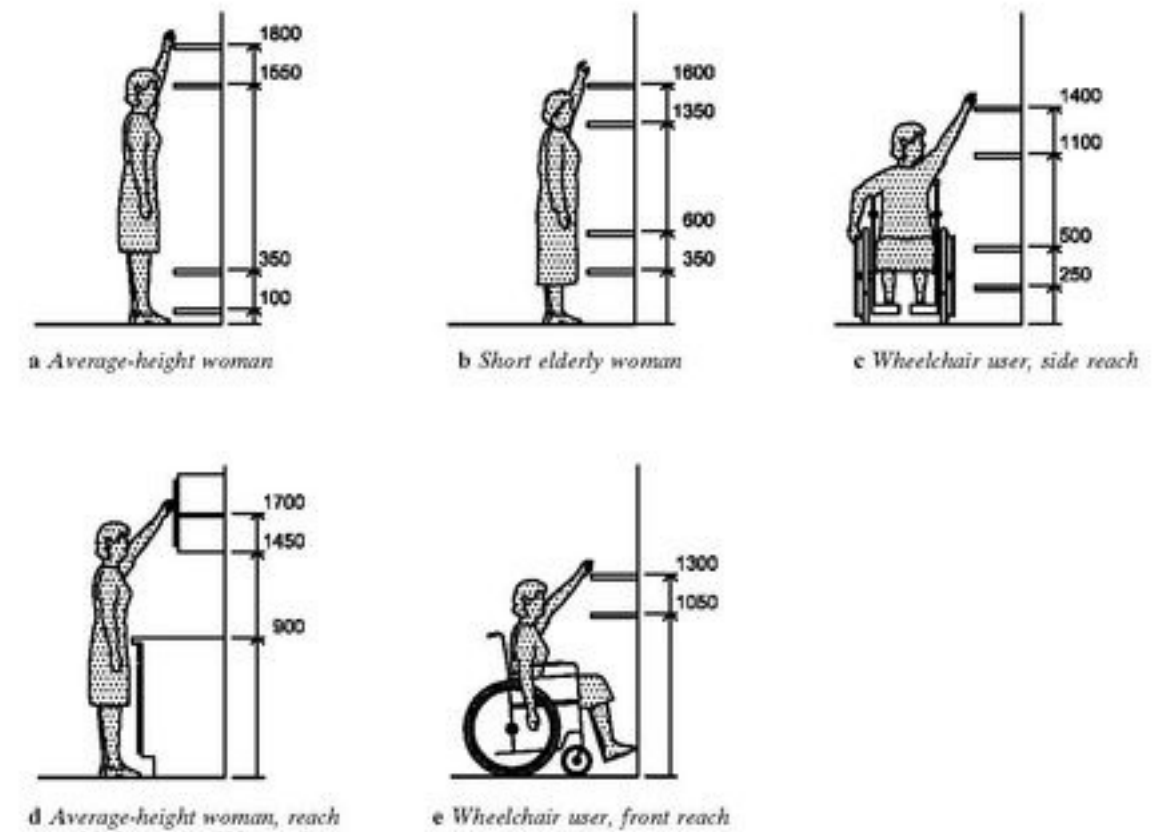

4.17 Reaches to shelves

Work surfaces and tables

Commentary page 33



- QUARTO - DIMENSIONAMENTO + FLUXO

Ana Carolina Junqueira
Andressa Valverde

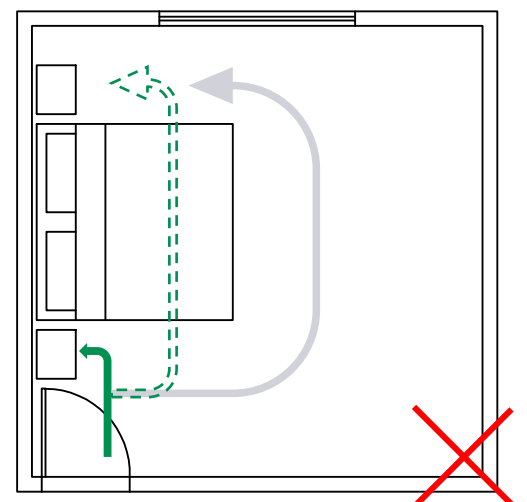
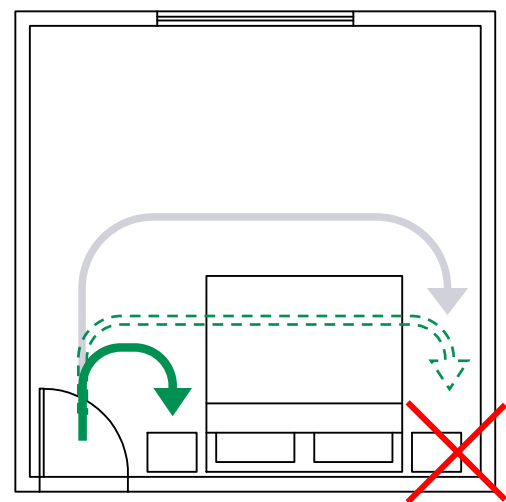
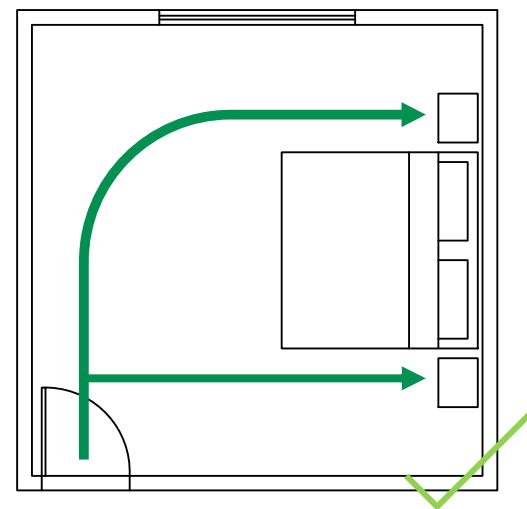
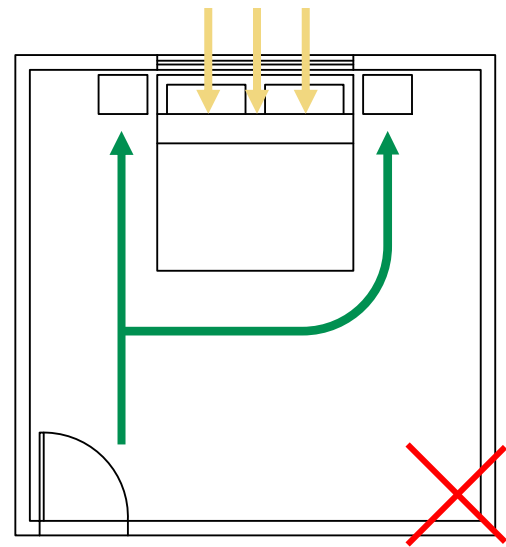

Medidas padrões no Brasil para colchões e cama box	
0,60 x 1,30 m	Berço Infantil
0,70 x 1,30 m	Berço Infantil
0,70 x 1,50	Berço Infantil
0,78 x 1,88 m	Solteiro
0,88 x 1,88 m	Solteiro
1,28 x 1,88 m	Casal
1,38 x 1,88 m	Casal
1,58 x 1,98 m	Queen Size
1,86 x 1,98 m	King Size
1,93 x 2,03 m	King Size

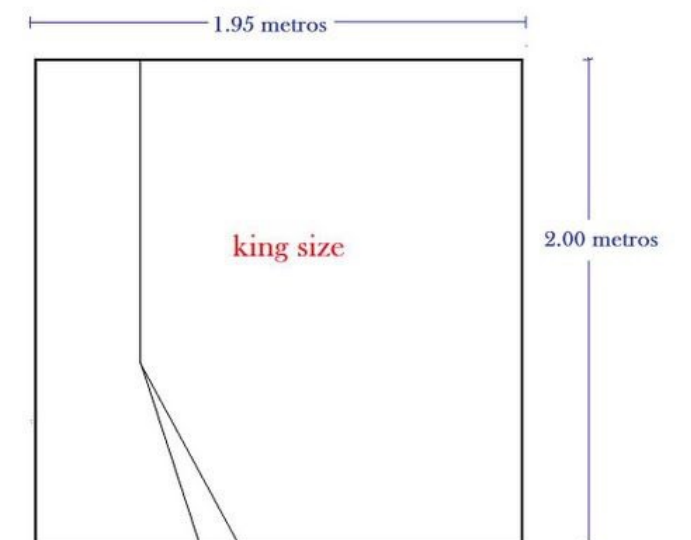
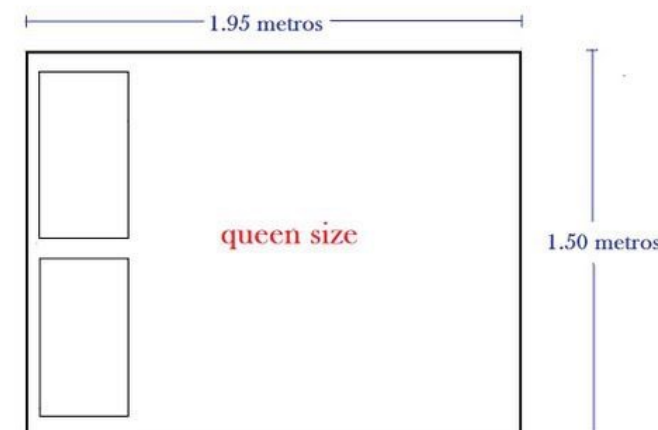
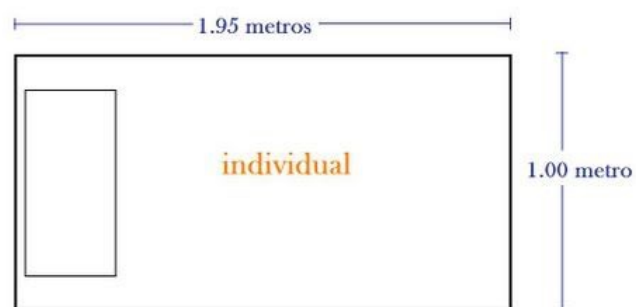

- QUARTO – DIMENSIONAMENTO + ERGO.

Ana Carolina Junqueira
Andressa Valverde

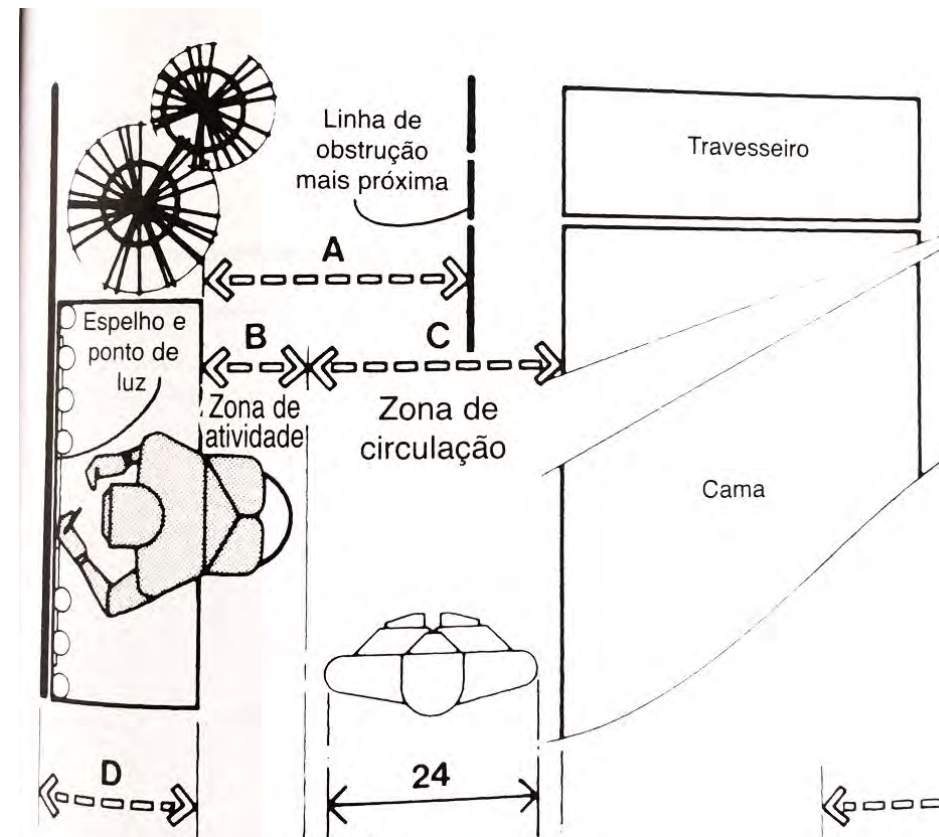
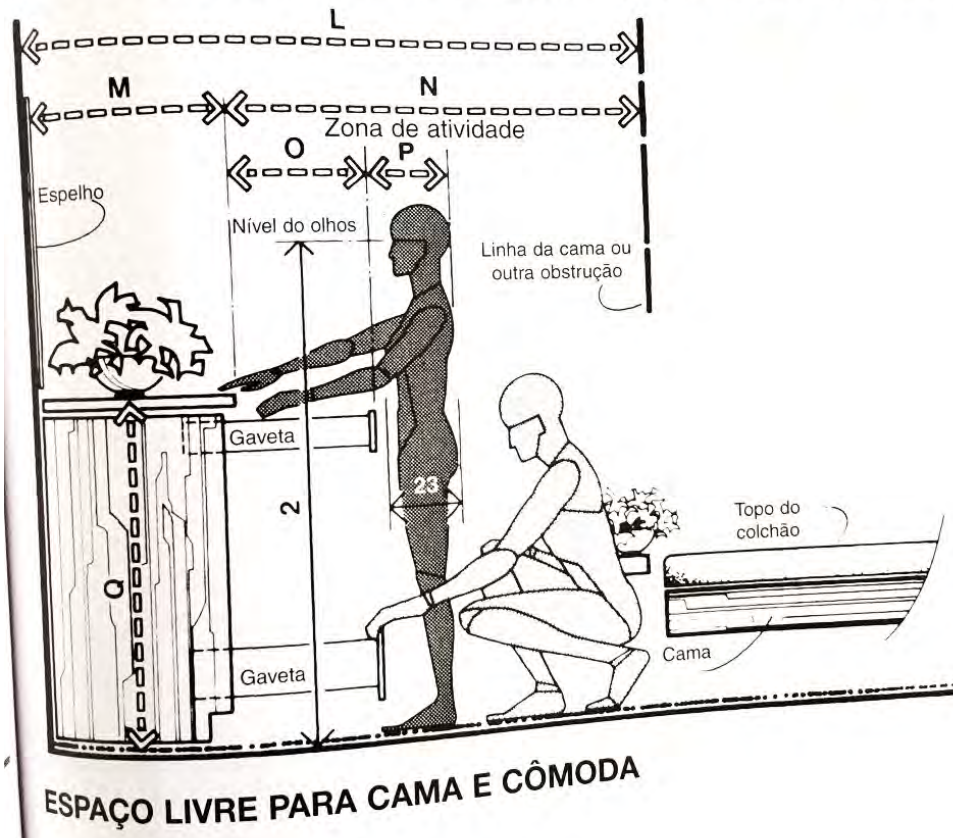

	cm
A	61,0-71,1
B	30,5-40,6
C	76,2
D	40,6-61,0
E	106,7-116,8
F	71,1-101,6
G	17,8 mín.
H	71,1-76,2
I	106,7-137,2
J	45,7-61,0
K	61,0-76,2
L	157,5-182,9
M	50,8-61,0
N	106,7-121,9
O	40,6-50,8
P	45,7
Q	106,7

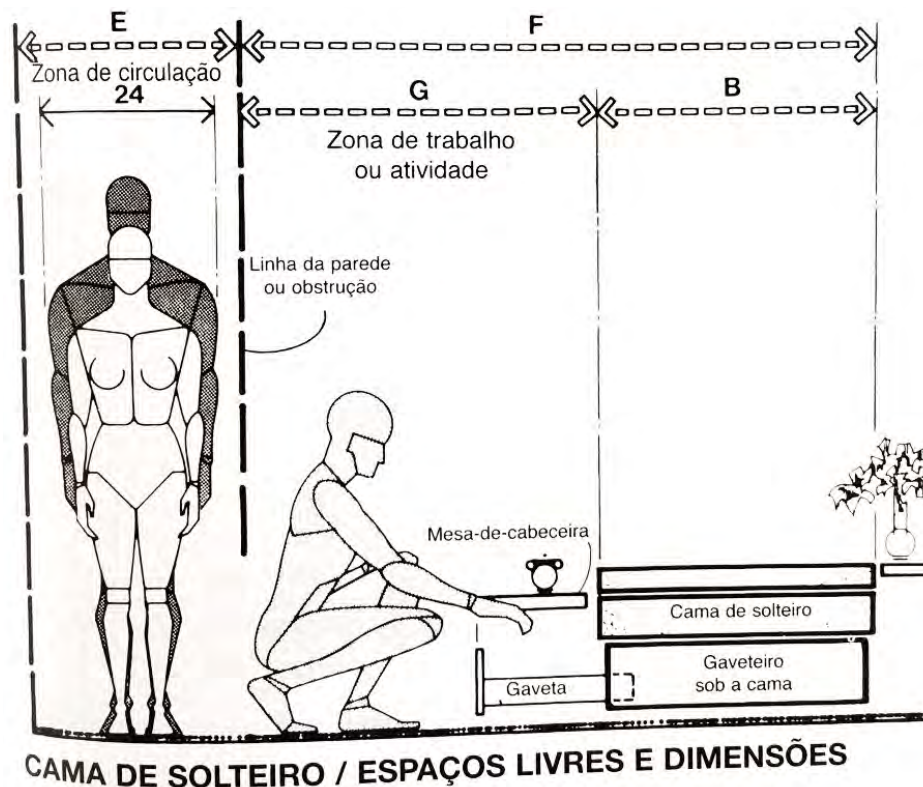
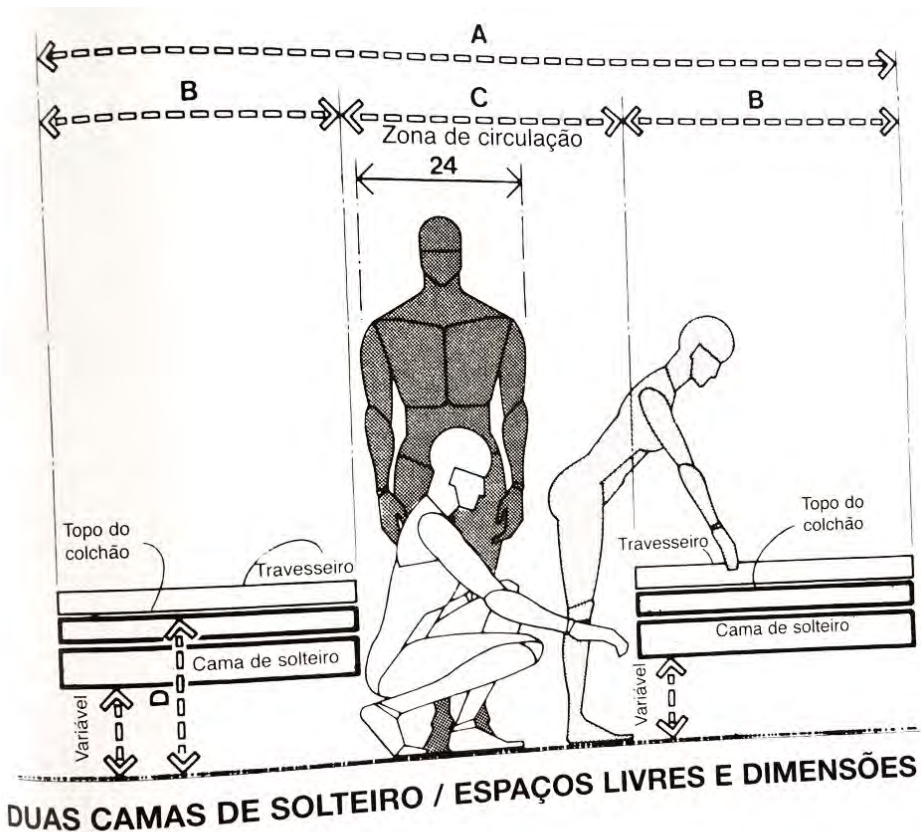

	cm
A	274,3-289,6
B	91,4-99,1
C	91,4
D	45,7-55,9
E	76,2
F	208,3-332,7
G	116,8-157,5

- QUARTO – DIMENSIONAMENTO + ERGO.

Ana Carolina Junqueira
Andressa Valverde

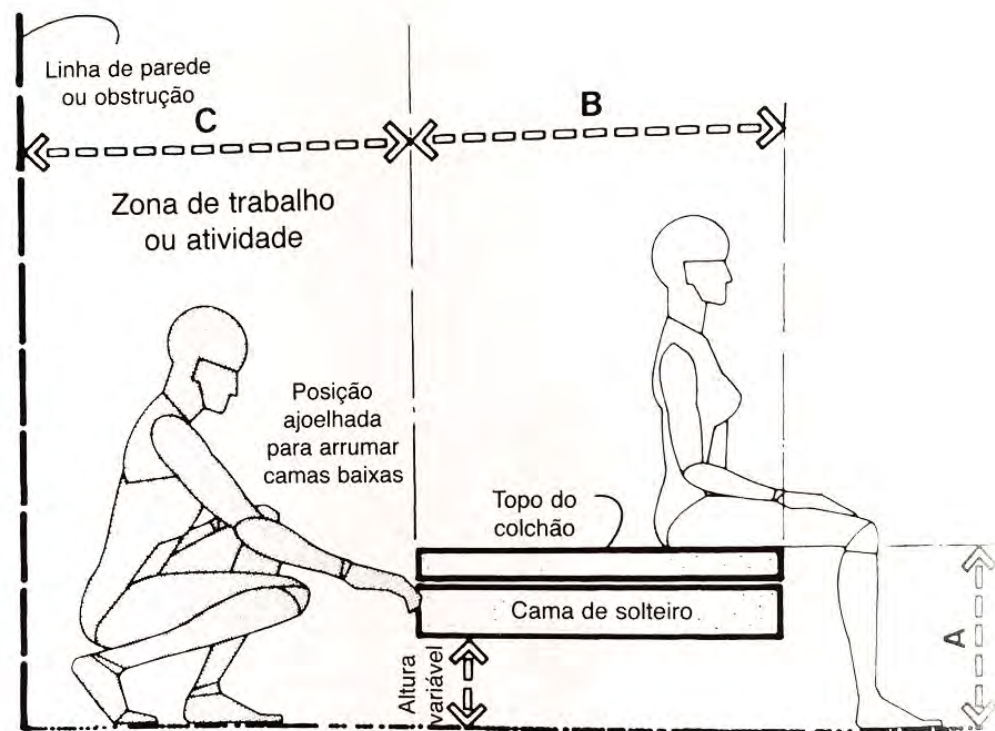

CAMA DE SOLTEIRO / DIMENSÕES E ESPAÇOS LIVRES

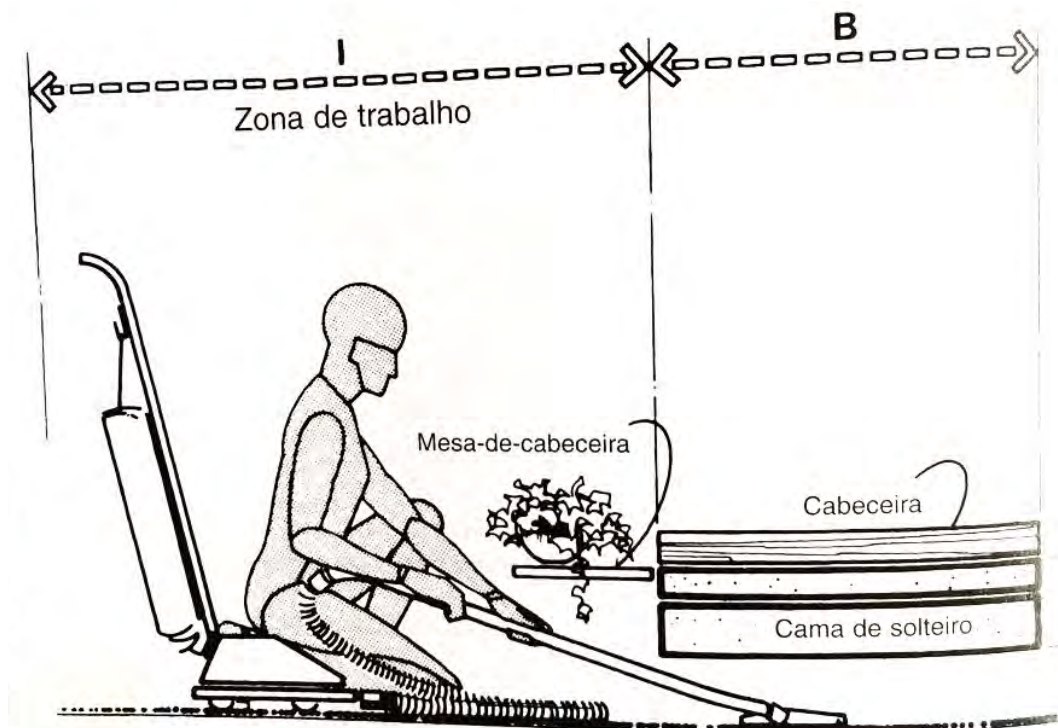

REQUISITOS PARA LIMPEZA

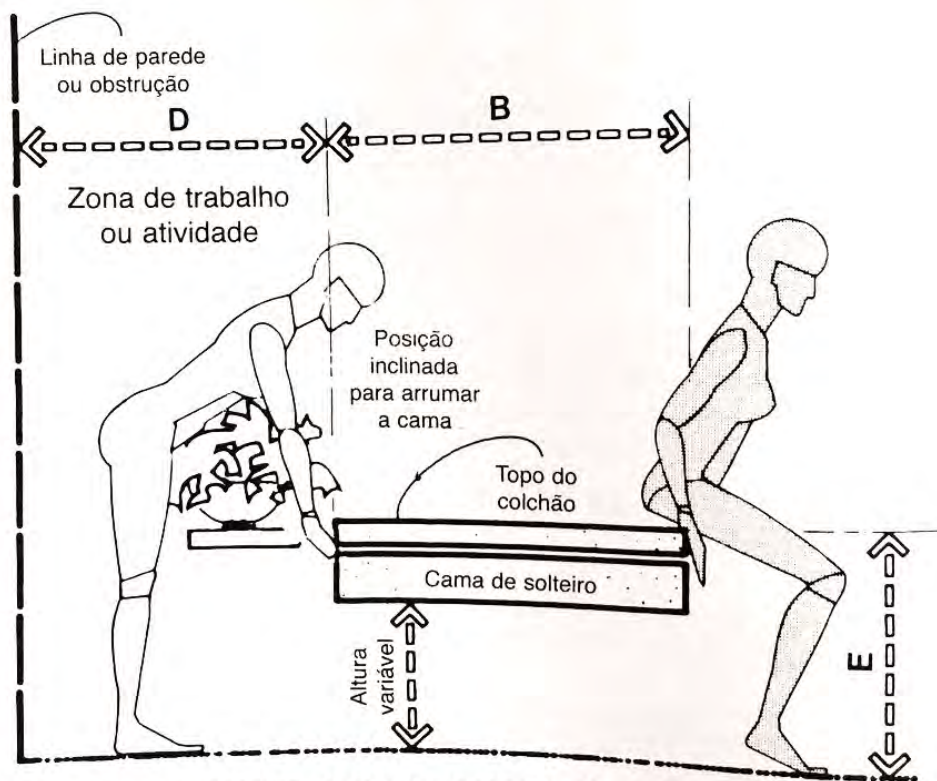

CAMA DE SOLTEIRO / DIMENSÕES E ESPAÇOS LIVRES

	cm
A	40,6
B	91,4-99,1
C	94,0-99,1
D	66,0-76,2
E	61,0
F	15,2-20,3
G	30,5-40,6
H	45,7-61,0
I	121,9-137,2

DIMENSIONAMENTO HUMANO PARA REPRESENTAÇÃO DE INTERIORES

- QUARTO – DIMENSIONAMENTO + ERGO.

Ana Carolina Junqueira
Andressa Valverde



QUAL TAMANHO DE TAPETE CABE DE BAIXO DE UMA CAMA QUEEN

QUAL TAMANHO DE TAPETE CABE DE BAIXO DE UMA CAMA KING

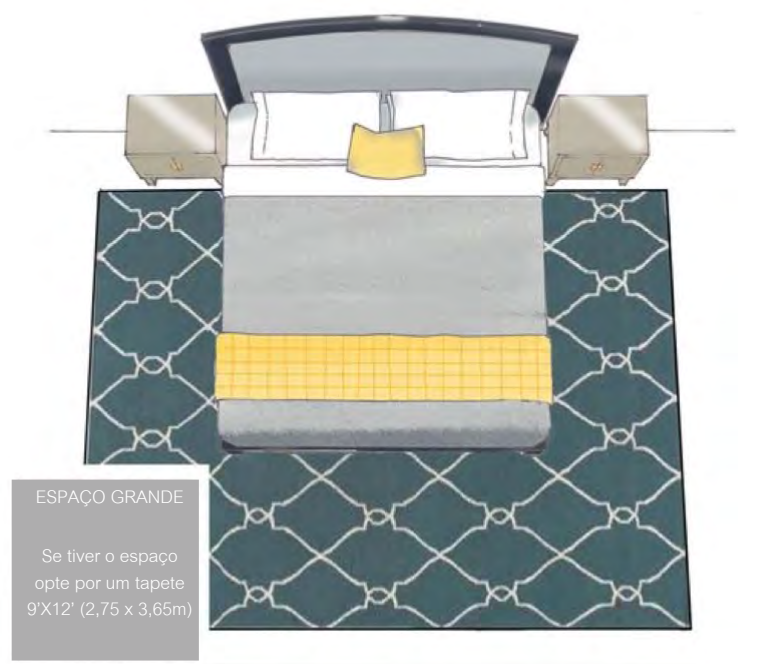
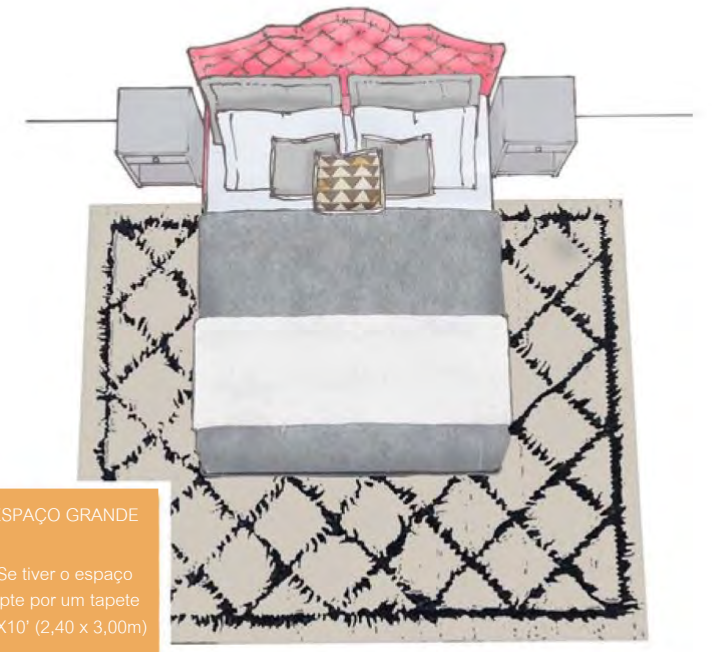
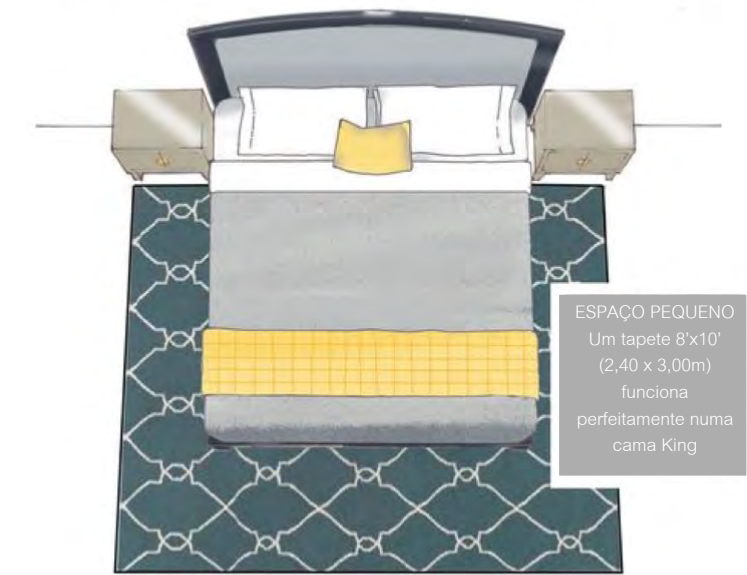
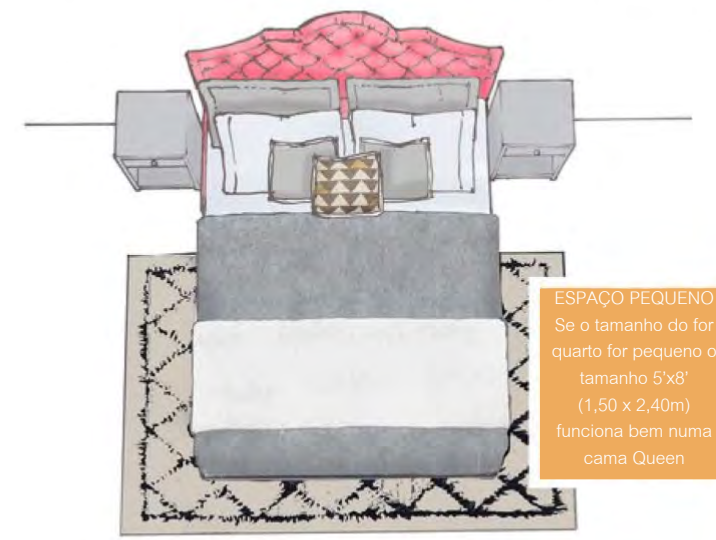
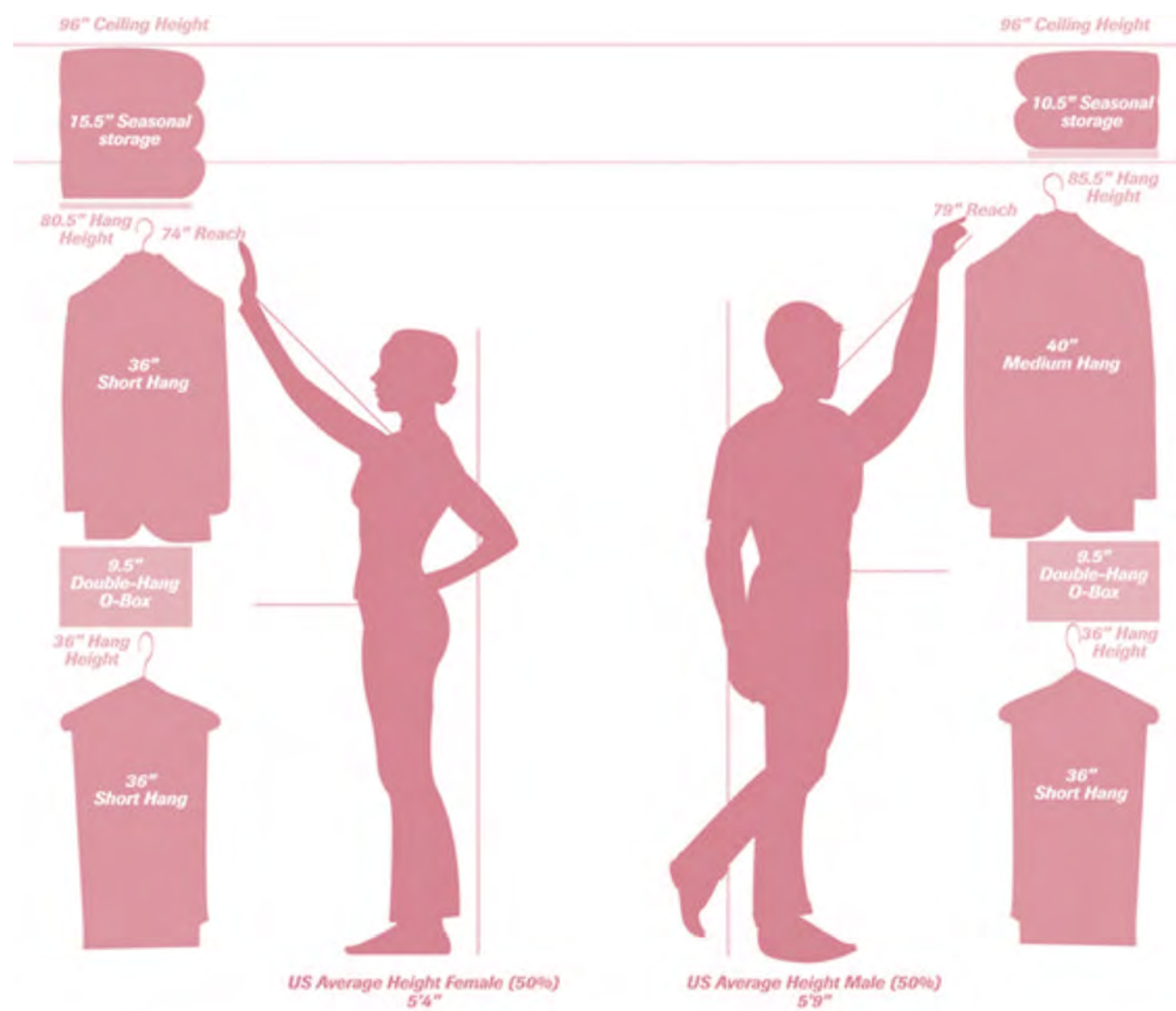
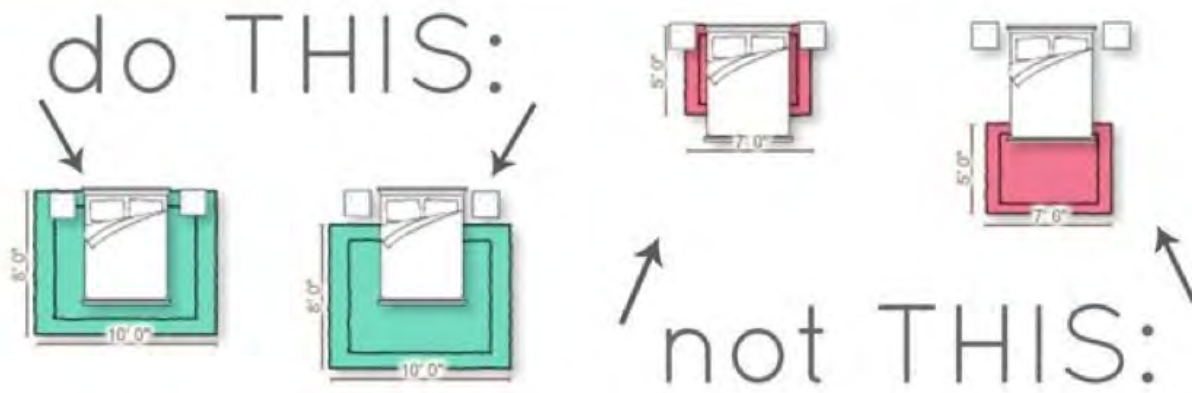

BIBLIOGRAFIA

- REFERÊNCIAS DE AULA -

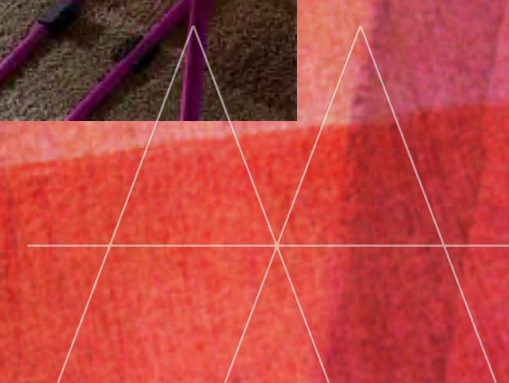
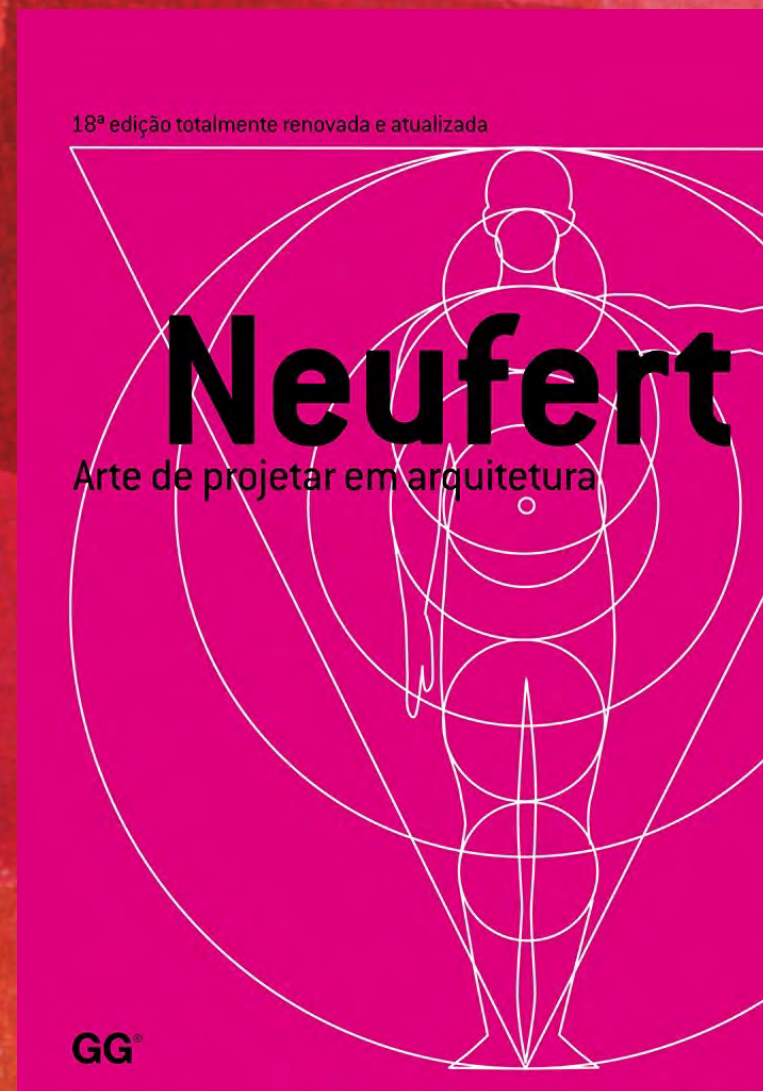



- Dimensionamento humano para espaços interiores – um livro de consulta e referência para projetos – 2014 – Julius panero, Martin zelnik – Ed. Gustavo Gil – 2014 10ª ed.
- Neufert, Peter e neff, Ludwig – casa, apartamento e jardim projetar com conhecimento construir corretamente – Ed. Gustavo Gil – 2008 2ª ed.
- Periódico casa Claudia, Kara
- <https://pt.wikipedia.org/wiki/Quarto>

QUARTOS

Exercícios de projeto

- Aula prática -



- QUARTO - EXERCÍCIO DE PROJETO

Ana Carolina Junqueira
Andressa Valverde



ESSÊNCIA MODERNA

(QUARTO CASAL)

Funções:

- RELAXAR → CAMA / TV / LUZ INDIRETA / CABECEIRA / LINHO
- DORMIR → CAMA / CORTINA
- TV → LUZ INDIRETA / CORTINA / CAMA / CABECEIRA
- TRABALHAR → ESCRIVANINHA / CADEIRA / LUMINARIA
- SE ARRUMAR → ARMÁRIO / ESPELHO / CABIDEIRO

CABIDEIRO DE TERNO P/ FACILITAR O DIA-A-DIA DO CLIENTE

DECORAÇÃO DO INTERIOR REFLETE A PERSONALIDADE ATIVA DO CLIENTE

USO DE TONS CLAROS E SERENOS

USO FREQUENTE DE MADEIRA REMETENDO CONFORTO

PALETA DE TEXTURA:

PALETA DE CORES:

REFERÊNCIAS

ARQUITETO? ANO? LOCAL?

PAINEL DE MADEIRA COMO CABECEIRA DA CAMA

ARQUITETO? ANO?

ARQUITETO? ANO? LOCAL?

LUZ COM FITA DE LED POR TRÁS DO PAINEL DE MADEIRA

ARQUITETO? ANO?

PAREDE CINZA

PALETA DE CORES COM BRANCO, CINZA E MADEIRA

REFERÊNCIAS

ESTRUTURA DE CORRER PARA CORTINA

CHÃO DE PORCELANATO LÍQUIDO

DESENHO DA PORTA DO ARMÁRIO

FORMA GERAL DO ARMÁRIO

- QUARTO - EXERCÍCIO DE PROJETO

Ana Carolina Junqueira
Andressa Valverde



INTERIORES RESIDENCIAIS T: 1
ANA J / GABRIEL M. / ANDRESSA V. / ANDERSON P.
QUARTO CASAL - PLATA BAIXA LAYOUT 21/09

INTERIORES RESIDENCIAIS T: 2
ANA J / ANDRESSA V. / ANDERSON P. / GABRIEL M.
QUARTO CASAL - VISTAS 1 E 2 21/09

INTERIORES RESIDENCIAIS T: 3
ANA J / GABRIEL M. / ANDRESSA V. / ANDERSON P.
QUARTO CASAL - VISTAS 3 E 4 21/09

- QUARTO - EXERCÍCIO DE PROJETO



Ana Carolina Junqueira
Andressa Valverde



QUARTOS
CONTEMPORÂNEOS
- PROJETOS EXECUTADOS -



- QUARTO CONTEMPORÂNEO - 2010'S +

Ana Carolina Junqueira
Andressa Valverde



DESIGN IDEA
Full circle. Round cribs nestle into small spaces with ease. Their unique silhouettes transform any nook into a nursery or rest gracefully in the center of the room. Subtly sophisticated, they are ideal for girls and boys alike.

RESTORATION HARDWARE



↑
Genuine feathers, each one meticulously hand placed on a framed, acid-free mat, create a delicate symbol of love.

RESTORATION HARDWARE

- QUARTO CONTEMPORÂNEO - 2010'S +



Ana Carolina Junqueira
Andressa Valverde



Pinterest



Pinterest



Pinterest

Quarto Infantil

- QUARTO CONTEMPORÂNEO - 2010'S +



Ana Carolina Junqueira
Andressa Valverde



FERNANDA MARQUES



FIGUEIREDO FICHER ARQUITETOS

- QUARTO CONTEMPORÂNEO - 2010'S +



Ana Carolina Junqueira
Andressa Valverde



Raw sunshine Coast



Pinterest

Quarto Infantil

- QUARTO CONTEMPORÂNEO - 2010'S +



Ana Carolina Junqueira
Andressa Valverde



ALESSANDRA AMADO



Pinterest

- QUARTO CONTEMPORÂNEO - 2010'S +



Ana Carolina Junqueira
Andressa Valverde



PAREDE DE
ESCALADA

Pinterest

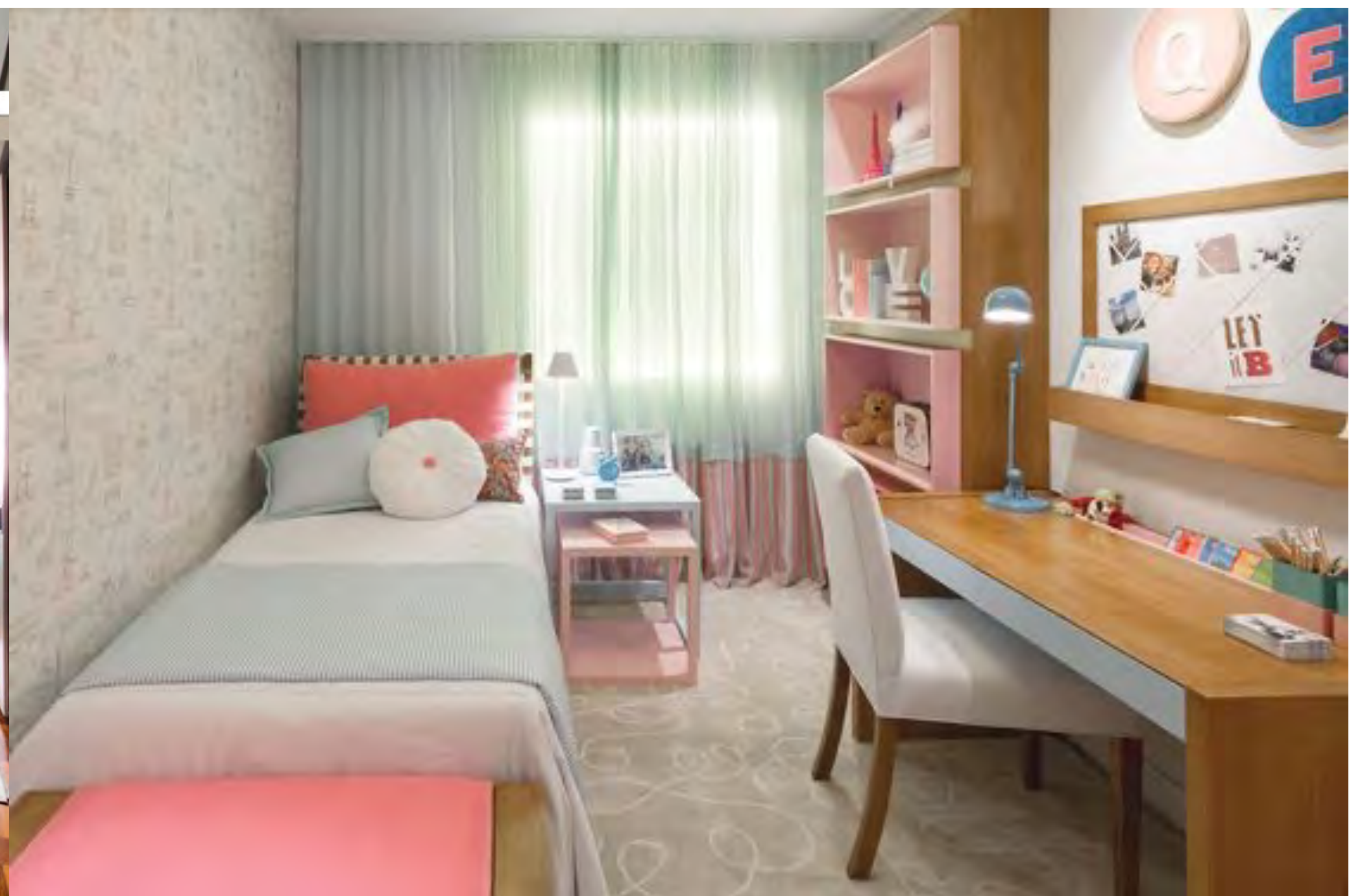

JULYANA BORTOLOTTI

Quarto Infantil

- QUARTO CONTEMPORÂNEO - 2010'S +

Ana Carolina Junqueira
Andressa Valverde



RESTORATION HARDWARE

RESTORATION HARDWARE

Quarto Compartilhado

- QUARTO CONTEMPORÂNEO - 2010'S +

Ana Carolina Junqueira
Andressa Valverde



→ Orbiting electrons energize our element art, creating a thought-provoking, vintage-inspired display.

RESTORATION HARDWARE



← Our spherical, swiveling lounger's plushly upholstered interior and aluminum-cast frame make it the ultimate place to land.

RESTORATION HARDWARE

Quarto Compartilhado

- QUARTO CONTEMPORÂNEO - 2010'S +

Ana Carolina Junqueira
Andressa Valverde



RESTORATION HARDWARE

RESTORATION HARDWARE

Quarto Compartilhado

- QUARTO CONTEMPORÂNEO - 2010'S +

Ana Carolina Junqueira
Andressa Valverde



RESTORATION HARDWARE

RESTORATION HARDWARE

Quarto Compartilhado

- QUARTO CONTEMPORÂNEO - 2010'S +



Ana Carolina Junqueira
Andressa Valverde



RESTORATION HARDWARE



RESTORATION HARDWARE

Quarto individual/CASAL

- QUARTO CONTEMPORÂNEO - 2010'S +



Ana Carolina Junqueira
Andressa Valverde



PINTEREST



LEILA DIONIZIO

Quarto individual/CASAL

- QUARTO CONTEMPORÂNEO - 2010'S +



Ana Carolina Junqueira
Andressa Valverde

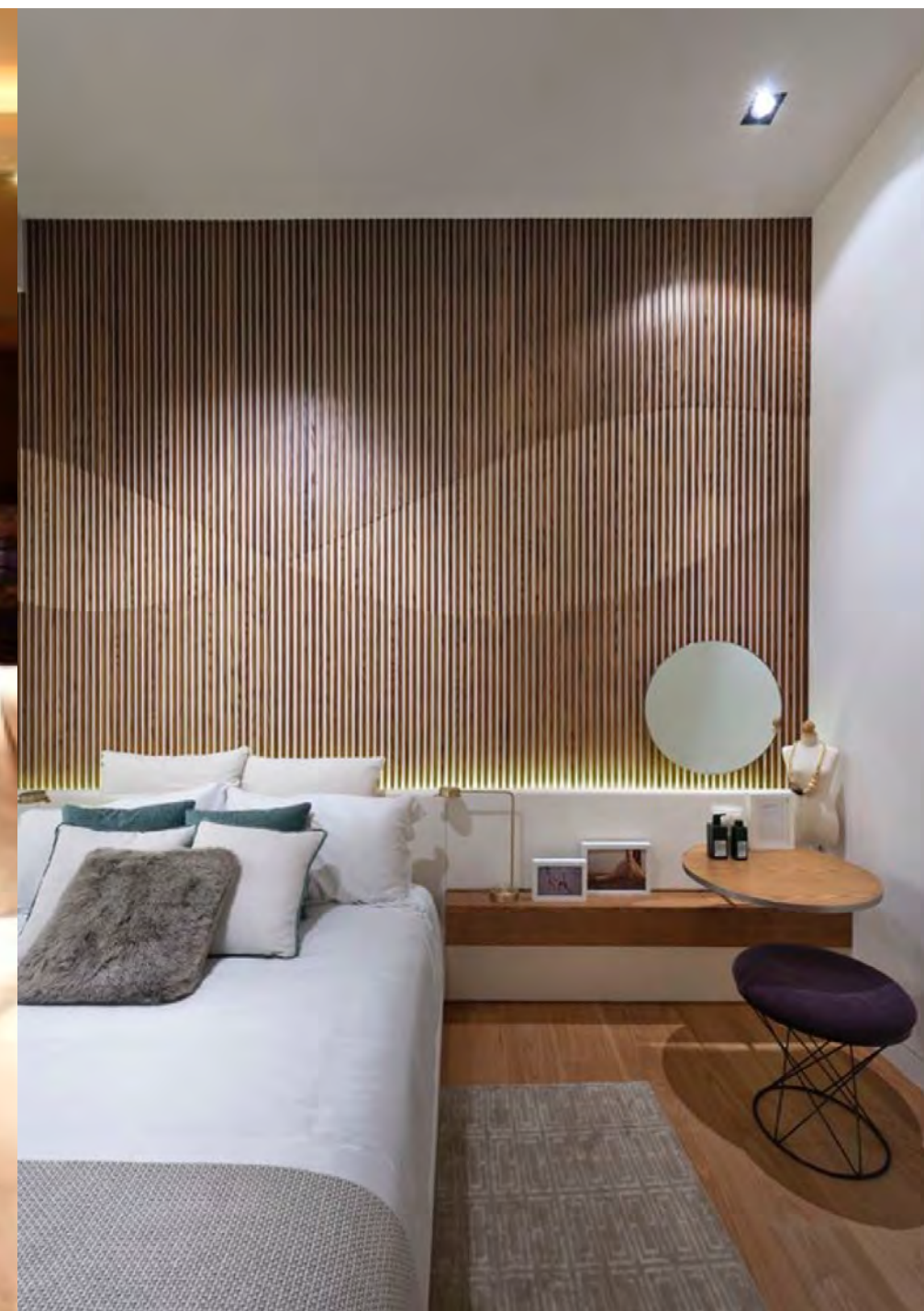

PINTEREST

PINTEREST

Quarto individual/casal

- QUARTO CONTEMPORÂNEO - 2010'S +



Ana Carolina Junqueira
Andressa Valverde



PINTEREST



Três arquitetura

Quarto individual

- QUARTO CONTEMPORÂNEO - 2010'S +



Ana Carolina Junqueira
Andressa Valverde

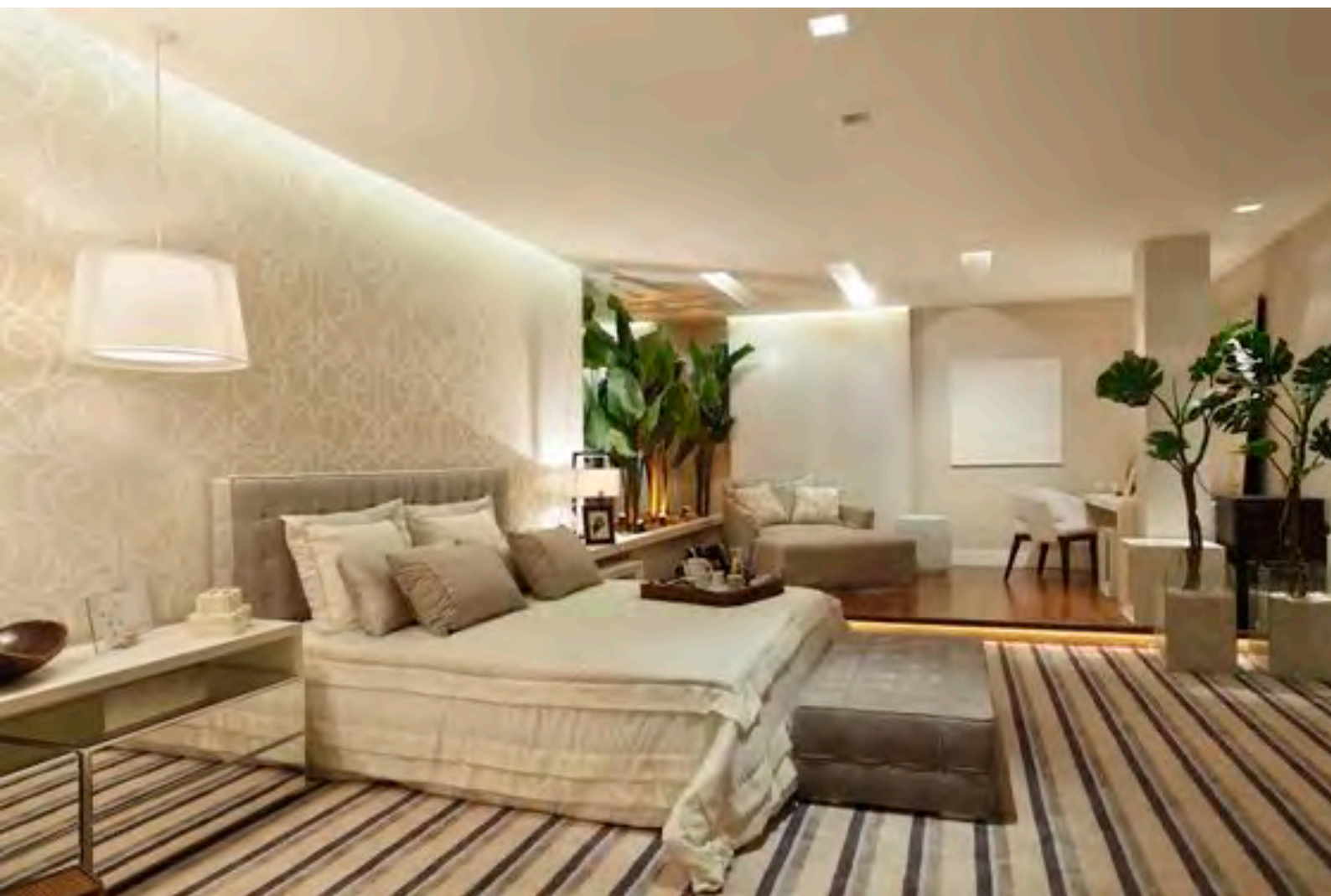

LEILA DIONIZIO



ANDRESSA FONSECA

Quarto individual/CASAL

- QUARTO CONTEMPORÂNEO - 2010'S +



Ana Carolina Junqueira
Andressa Valverde



LEILA DIONIZIO



Pinterest

Quarto individual/CASAL

- QUARTO CONTEMPORÂNEO - 2010'S +



Ana Carolina Junqueira
Andressa Valverde



RH TEEN

RESTORATION HARDWARE



RESTORATION HARDWARE

Quarto Individual

- QUARTO CONTEMPORÂNEO - 2010'S +



Ana Carolina Junqueira
Andressa Valverde



PINTEREST

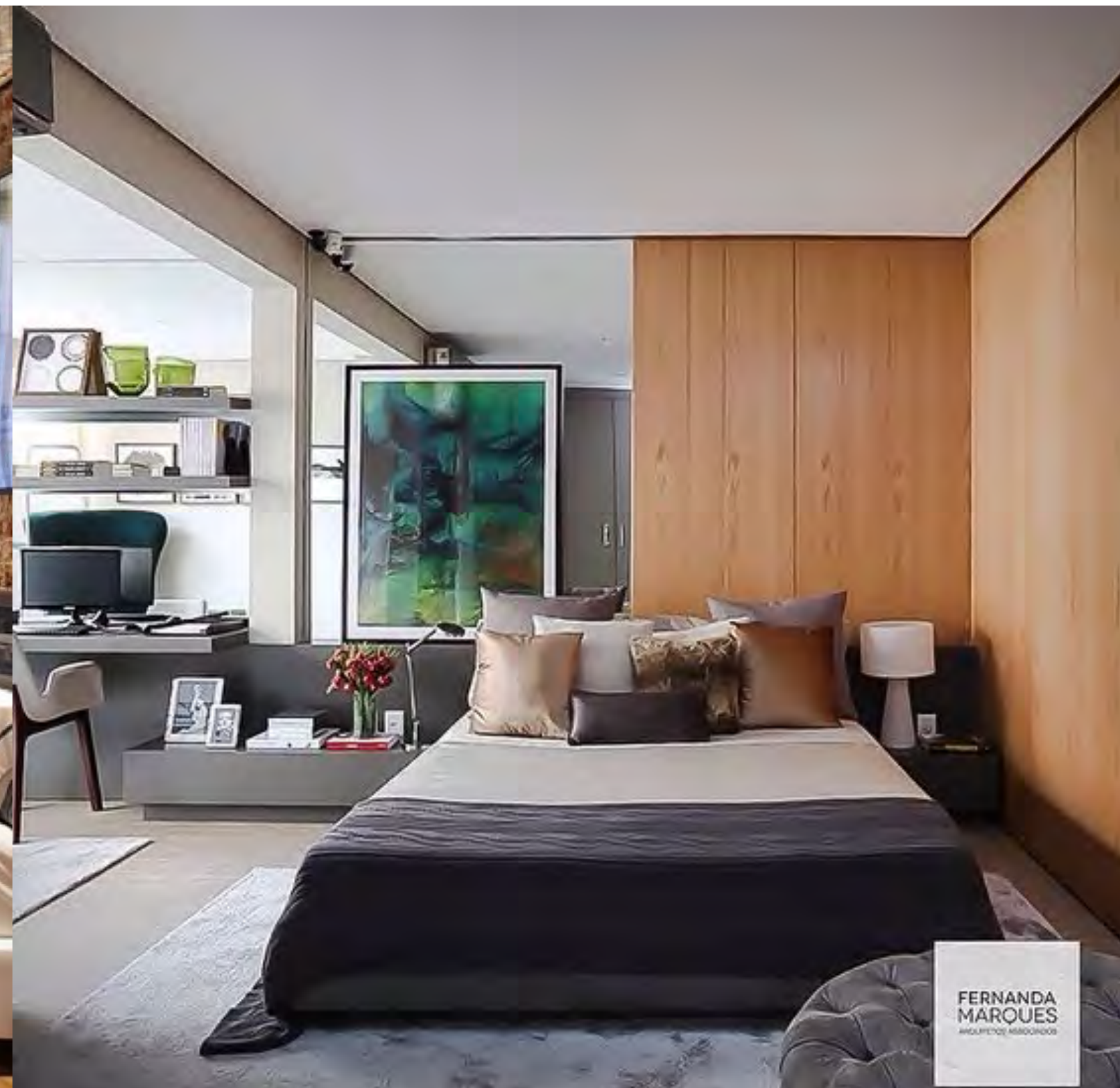

FERNANDA MARQUES

Quarto Individual/CASAL

- QUARTO CONTEMPORÂNEO - 2010'S +



Ana Carolina Junqueira
Andressa Valverde



RESTORATION HARDWARE



RESTORATION HARDWARE

Quarto Individual/casal